

Installation advice:

The ease of use of your manipulator depends on its good installation.
A SAPELEM expert studies the installation in order to guarantee the optimal ergonomics of the workstation.

Examples of using pallets turnaround:

Gripping pallet on conveyor

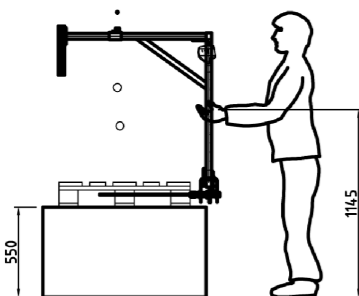

Releasing pallet on the ground

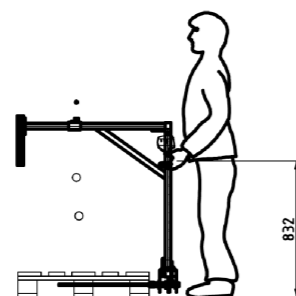

Releasing turned pallet

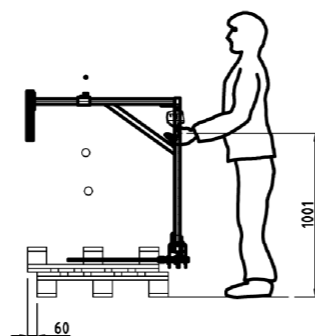

Releasing pallet

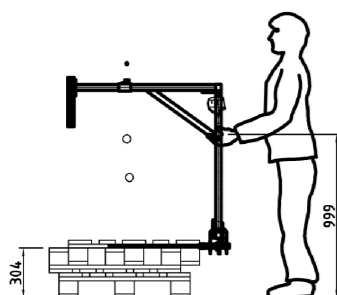

Max transfer height

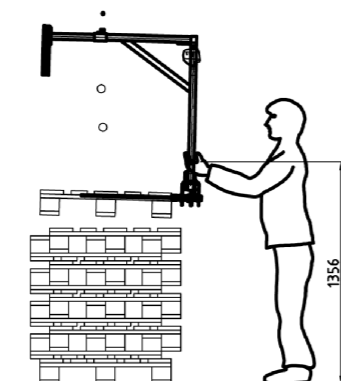

Releasing last pallet

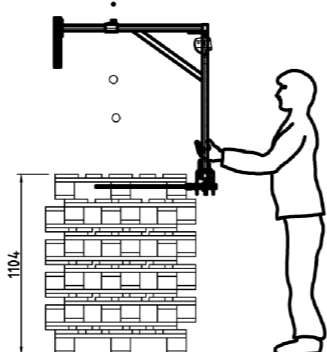

S269 3 M01 D



SAPELEM is studying and manufacturing other gripping solutions:

- Suction cups
- Clamps
- Magnets

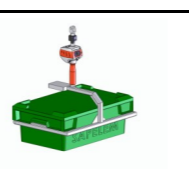

ZE' SOLUTION ERGONOMIC MANIPULATOR

Technologies:

- Aluminium arm with low-inertia double articulation
- Electronic lifting assistance to intuitively lift loads up to 200kg with only 20g effort

Advantages:

- Versatility: handling many products
- Precision: sensitive Zii handle
- Rapidity: optimal working pace
- Ergonomics: RSI removal
- Intuitiveness: naturally following hand movement without button
- Safety: secured grip-release, alarms, hand detection

Customized:

- Wide work zones: possible to install under rail, framework, or under a supporting structure
- Heavy loads: steel arm enabling the handling of loads up to 300kg
- Services: installation and ergonomics expertise
- Special: manipulator conception and manufacturing for specific applications



SAPELEM has created a wide range of standard manipulators answering the most common applications.

ZE' SOLUTION PALLETIZER

Function:

Palletizing or depalletizing pallets

Advantages:

- Productivity: high handling pace
- Ease: effortless handling, preserves the back
- Versatility: turnaround for "top to tail" storage

Description:

- Pallets turnaround system in option
- Ergonomic, long and off-centred control handle

Minimal required configuration:

- ZE'Solution Basic



In line with European Standard EN14238

Use:
Palletizing or depalletizing pallets

Advantages:
Ideal ergonomics: extended and off-centred handle
Lightness: high resistance steel
Capacity: handling up to 3 pallets

Use:
Stocking or unstocking "top to tail" pallets
Inspecting and repairing pallets

Advantages:
Effortless manual turnaround of the pallet
Ideal ergonomics: extended and off-centred handle
Lightness: high resistance steel
Safety: automatic indexing every 180°

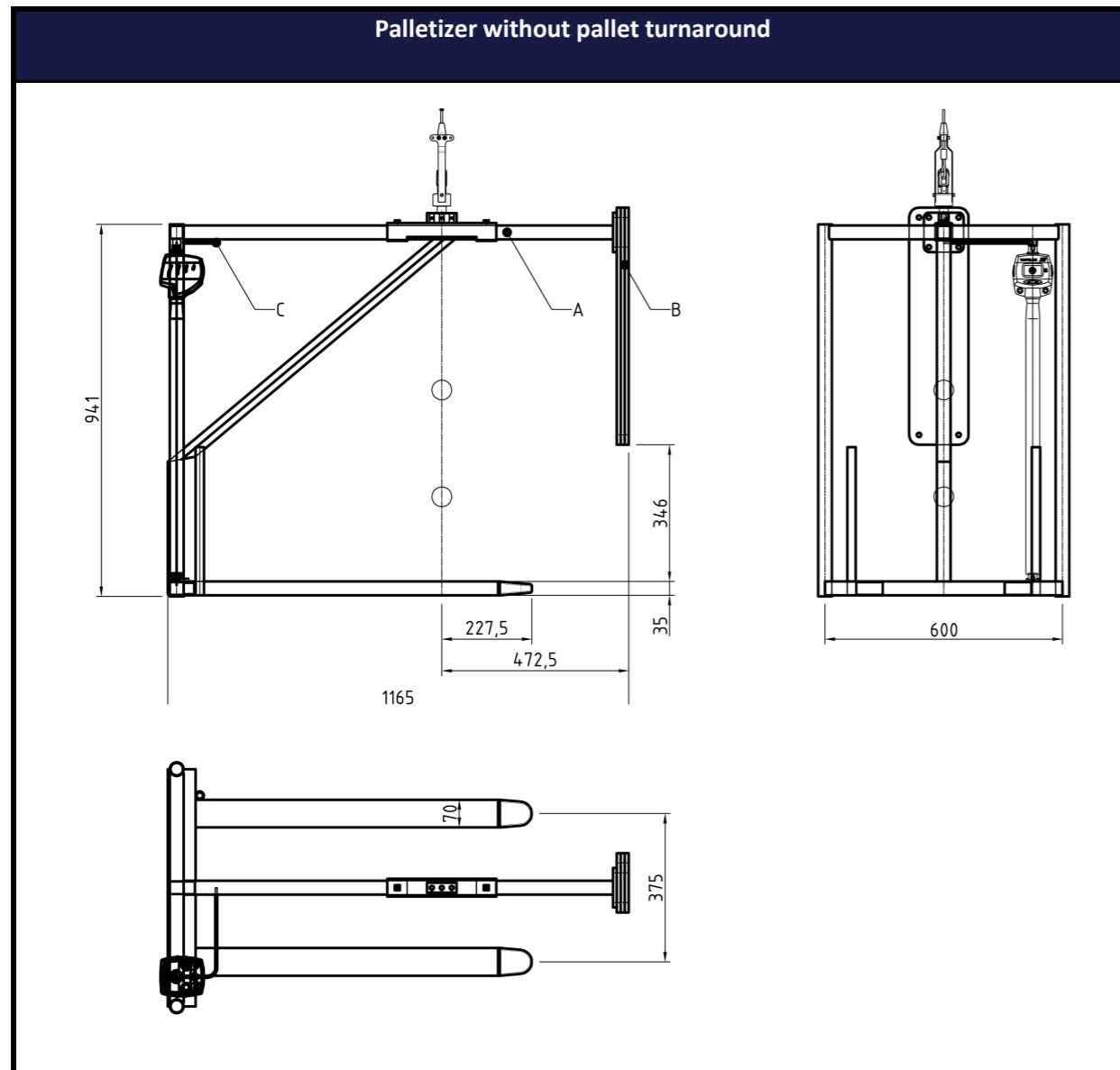

WLL	Reference without turnaround	Empty weight
40kg	5ZADF08011	68kg

Characteristics:

- Pace: about 20s per pallet (depending on the moving to do)
- Long handle for grip/release on the ground
- Balancing counterweight developed to avoid taking more than 3 pallets at once

Recommended balancer: ELS 130

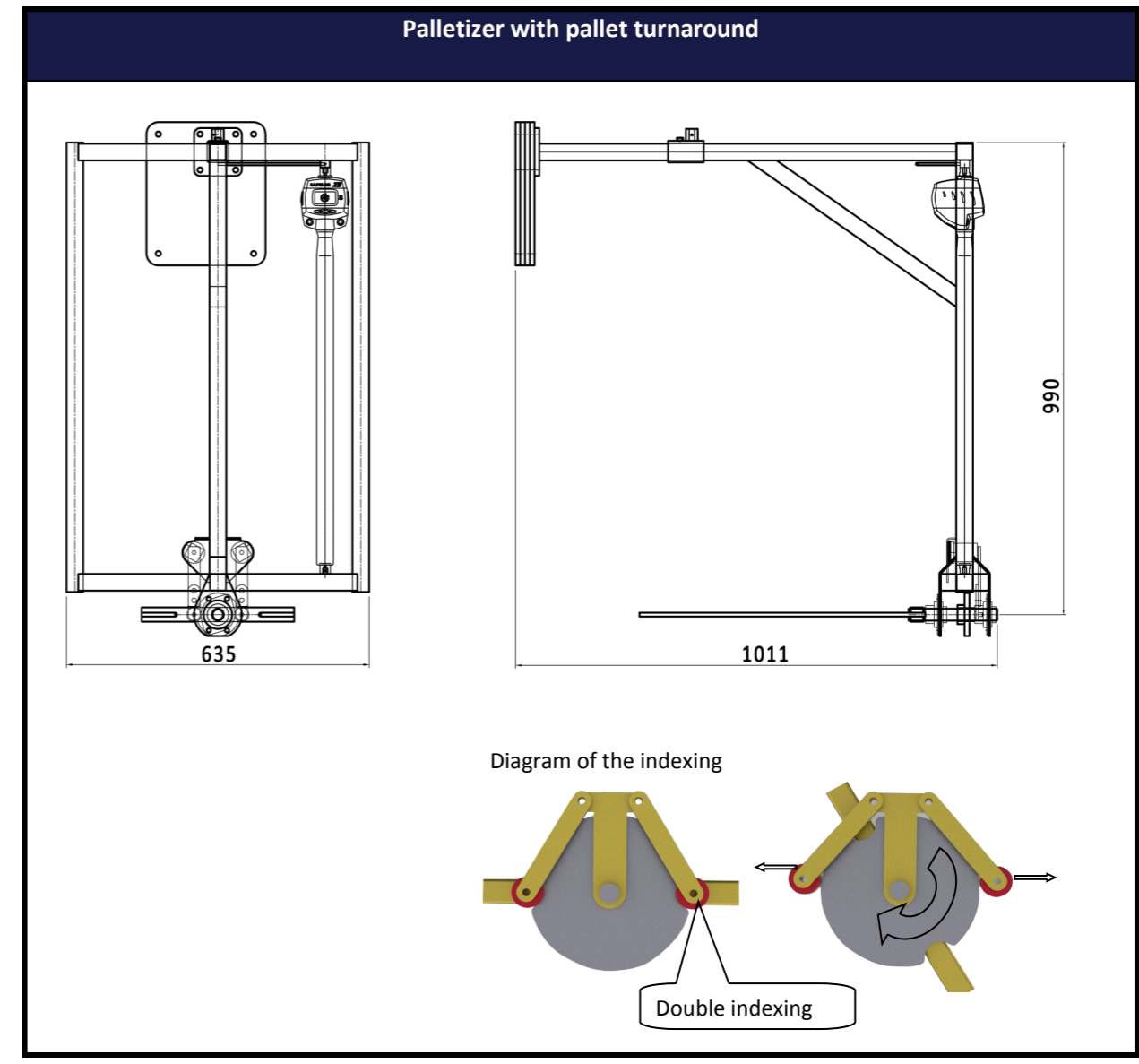

WLL	Reference with turnaround	Empty weight
40kg	5ZADR04011	74kg

Characteristics:

- Manual turnaround with automatic indexing
 - ⇒ Free 360° rotation with indexing every 180° by spring connecting rods
 - ⇒ Double side forks to take the next pallet without going back
 - ⇒ Long handle for grip/release on the ground
 - ⇒ Pace: about 25s per pallet, including turnaround (depending on moving)

• Option: adjustable forks

Recommended balancer: ELS 130